

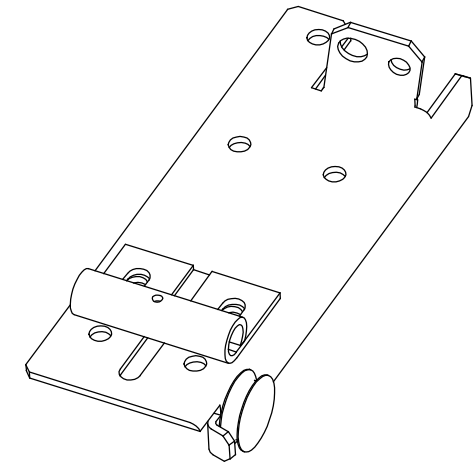

Änderungen			
REV	Beschreibung	Datum	Genehmigt

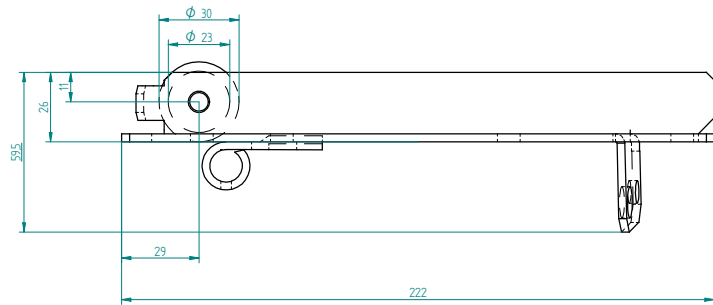
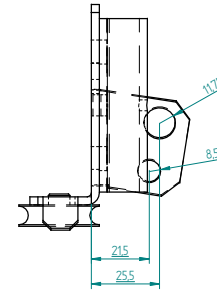
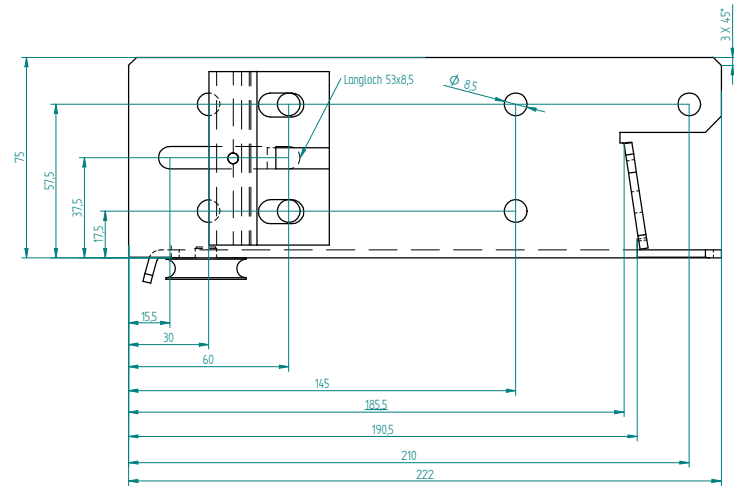

Bestell-Nr.: 1072 Zink Nickel
 Bestell-Nr.: 1117 Galv. verzinkt

Gezeichnet	Name Theimer	Datum 19.03.08	Stanztechnik Hain <small>35634 Dillenburg</small> 
Geprüft	Theimer	19.03.08	
Toleranz: DIN 2768 m			<small>Größe A1</small> Zeichn.Nr. 06301072 <small>REV</small>
Material: 10332			Teil:
Oberfläche:			<small>Massstab</small> <small>Gewicht</small> <small>Blatt 1 von 1</small>